

**PIENAAR ENERGY (PTY) LTD**

# **Promotion of 100kWh outdoor photovoltaic cabinets for schools**



## Promotion of 100kWh outdoor photovoltaic cabinets for schools

---



### 1928 26th Ave E, Seattle, WA 98112 , Redfin

3 beds, 2.5 baths, 2696 sq. ft. house located at 1928 26th Ave E, Seattle, WA 98112 sold for \$737,500 on . MLS# 461364. A covered rocking chair front porch welcomes you into ...

[Get Price](#)

---

### 1928 26th Ave E Seattle WA 98112 Property Details & Valuation

1928 26th Ave E Seattle WA with 2 bedroom and 1 bath is currently not for sale. Xome's estimated value is 1671122. Discover more property details at Xome .



[Get Price](#)

---

### 50kw/100kwh Outdoor Cabinet Energy strage system

Our product can obtain local load power in real time, the photovoltaic power is self-use first, and the left power is stored; When the power generated by photovoltaic power generation is insufficient to ...



[Get Price](#)

---

## 1928 26Th Ave E, Seattle, WA 98112

1928 26th Ave E, Seattle, WA 98112 - 2,696 sqft home built in 1916 . Browse photos, take a 3D tour & see transaction details about this recently sold property. MLS# NWM461364.

[Get Price](#)

### Lithium battery parameters

Product capacity: 100Ah

Product size: 135\*197\*35mm

Product weight: 1.82kg

Product voltage: 3.2V

internal resistance: within 0.5



## SUNWAY 50-100kW Outdoor Cabinet Energy Storage System With ...

The outdoor cabinet is weatherproof, easy to install, and built for long-term performance. With remote monitoring, after-sales service, and extended warranty, SUNWAY ensures stable power supply and ...

[Get Price](#)

## 1928 26th Ave E, Seattle, WA 98112 , RealtyTrac

2 Bedrooms, 4 Bathrooms, Single Family Home - Off Market Property in Seattle, Washington. This home was built in 1916, is 2040 square feet, and its expected value is \$1,454,082.776

[Get Price](#)



## 50kW/100kWh outdoor All-in-one all-in-one cabinet ...



50kW/100kWh outdoor cabinet ESS solution (KAC50DP-BC100DE) is designed ...

[Get Price](#)

## 100 KWh-500KWh Solar Battery Storage Cabinet, 100kWh Battery ...

This integrated solar battery storage cabinet is engineered for robust performance, with system configurations readily scalable to meet demands such as a 100kwh battery storage requirement.

[Get Price](#)



## Sunpal Outdoor Cabinet Energy Storage System 100Kw 100kWh ...

What are the applicable scenarios of the outdoor integrated cabinet?---Outdoor integrated cabinets are suitable for various outdoor environments, such as communication base stations, power substations, ...

[Get Price](#)

## 1928 26th Ave E, Seattle, WA 98112 , Zillow

1928 26th Ave E, Seattle, WA 98112 is currently not for sale. The 2,696 Square Feet single family home is a 3 beds, 4 baths property. This home was built in 1916 and last sold on 2013-04-19 for \$737,500. ...

[Get Price](#)



## 1928 26th Ave E, Seattle, WA 98112

1928 26th Ave E, Seattle, WA 98112 is a 2,696 sqft, 3 bed, 4 bath home sold in 2013. See the estimate, review home details, and search for homes nearby.

[Get Price](#)

## 100kwh Energy Storage System Outdoor Integrated Cabinet

Our photovoltaic energy storage systems represent clean energy solutions that help reduce greenhouse gas emissions and lower carbon footprints. Furthermore, we actively engage in environmental and ...

[Get Price](#)



## 1928 26th Ave E Seattle, WA 98112

1928 26th Ave E is a Single Family Home



located in the Montlake area of Seattle, WA 98112. It is part of King County and identified by Assessor's Parcel Number (APN) 871210-0475.

[Get Price](#)

---

## 50kW/100kWh outdoor All-in-one all-in-one cabinet energy

50kW/100kWh outdoor cabinet ESS solution (KAC50DP-BC100DE) is designed for small to medium size of C&I energy storage and microgrid applications. Individual pricing for large scale projects and ...

[Get Price](#)



---

## Home for sale in Seattle: 1928 26th Ave E, Seattle, WA 98112

3 bed, 3 bath, 2,696 SQFT house. A covered rocking chair front porch welcomes you into this spacious Montlake craftsman with period details int .

[Get Price](#)

---

## Hoenergy Power

Explore high voltage battery packs, wall mounted lithium batteries, and ESS cabinets from Hoenergy -- your 2025

Global Tier 1 Energy Storage Provider.

[Get Price](#)



## 100KWh Outdoor Cabinet Series Energy Storage System

The HighJoule 100KWh Outdoor Cabinet Series offers a robust solution for commercial applications, featuring a 100KWh LFP or SSB battery with over 8000 cycles, ensuring long-term reliability and ...

[Get Price](#)

## 26th Ave E, Seattle, WA 98112 Property Records

26th Ave E in Seattle, WA 98112 has 251 properties with an average market value of \$1,169,045. These homes, built between 1901 and 2021, typically offer 1-7 bedrooms and 1-6 bathrooms. Property ...

[Get Price](#)



## 50KW / 100KWH Outdoor Cabinet Energy Storage System

Our 50KW/100KWH outdoor cabinet energy storage system, with its excellent performance and thoughtful design, is the ideal choice for outdoor energy storage applications.

[Get Price](#)

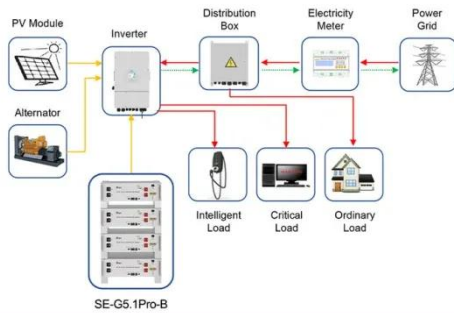

Application scenarios of energy storage battery products

## KSTAR Commercial 50 kW / 100 kWh Solar Battery Storage System

50kW / 100kWh Outdoor All-in-one Battery Storage Cabinet Designed for SMEs: garden centres, farm shops, schools, zoos, pubs, restaurants, micro-breweries and solar car parks



[Get Price](#)

## Contact Us

For catalog requests, pricing, or partnerships, please visit:  
<https://www.pienaarshof.co.za>

