

Photovoltaic panel export trade



SMART GRID & HOME



Overview

Combined with the latest international trade information in 2025 (such as HS code confirmation, Tax Rebates Adjustments, tariff developments, and quality-standard requirements), we have compiled a practical guide. It is designed to help you conduct business more smoothly and. India is a major supplier of solar panels to the US, with 97% of its module exports, totaling 10.4 GW, destined for the US in the first nine months of 2025. Interestingly, the trade deal came weeks after the US pulled out of the International Solar Alliance, backed by India. "The. China has invested over USD 50 billion in new PV supply capacity - ten times more than Europe - and created more than 300 000 manufacturing jobs across the solar PV value chain since 2011. Tariffs are falling, making Indian solar modules and cells more competitive. This move is expected to drive capacity. Solar photovoltaic (PV) manufacturing involves making a wide variety of products and materials across several manufacturing steps, often done in different locations. It was previously as high as 50%.

Photovoltaic panel export trade



US tariffs, Europe slowdown reshape global solar panels trade

Solar panel exports from Vietnam, Malaysia, Thailand and Cambodia to the U.S. fell by 33% on an annual basis in the nine months since the first round of tariffs in June. In the same period,

[Get Price](#)

Global solar PV supply chain

Between 2025 and 2029, global solar photovoltaic capacity additions are projected to increase yearly and range from some 655 gigawatts in 2025 to 930 gigawatts in 2029.

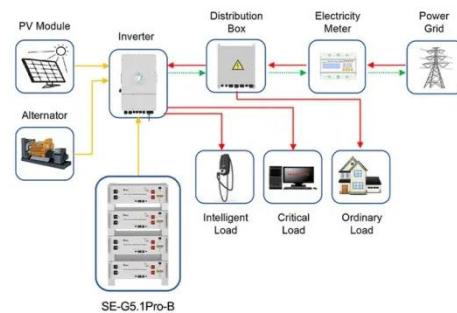

Application scenarios of energy storage battery products

[Get Price](#)

BASIC APPLICATION

Storage systems have been proven to be "extremely lucrative" for commercial and industrial (C&I) filed.

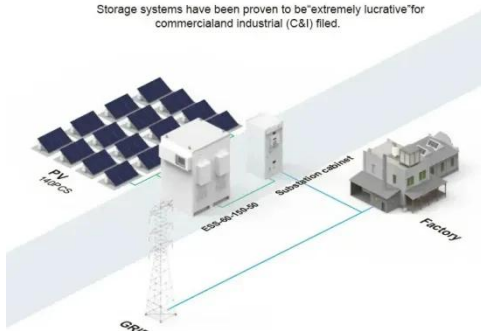

Tariff cut sparks optimism across solar panel makers and exporters

Top solar panel makers said that the trade deal with the United States will boost Indian solar exports to the US and help them integrate into global supply chains. The deal will bring down ...

[Get Price](#)

Executive summary - Solar PV Global Supply Chains

Solar PV products are a significant export for China. In 2021, the value of China's solar PV exports was over USD 30 billion, almost 7% of China's trade surplus over the last five years.

[Get Price](#)

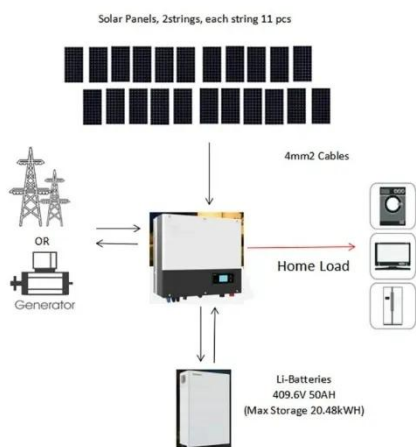

Overview of Trade and Policy Measures for U.S. Solar Manufacturing

What Trade Measures Exist Today? A variety of trade measures impact the growth of U.S. solar manufacturing, targeting both domestic and foreign stakeholders at different points in the supply chain.

[Get Price](#)

Photovoltaic Components Export Guide: HS Codes, Declaration ...

Detailed explanation of the core rules for the export of photovoltaic modules, including HS classification (assembled modules under 8541430000), declaration elements, international FTA ...

[Get Price](#)



Impact of US trade barriers on

solar PV supply chain: challenges and



In terms of tariff rates alone, Turkey, Indonesia, and India seem to have the most favorable conditions for exporting cells and modules to the U.S., offering a cost-performance ...

[Get Price](#)

Top Indian Solar Panel Maker Sees US Trade Deal Reviving Exports

Saatvik Green Energy Ltd., one of India's top solar panel makers, said it expects the country's trade deal with the US to revive exports of solar products to the world's largest economy.

[Get Price](#)



US India trade deal: Solar equipment makers recharge exports ...

Indian solar equipment exports to the US are set for a significant boost. Tariffs are falling, making Indian solar modules and cells more competitive. Companies are now planning to export ...

[Get Price](#)

US-India trade agreement reduces general tariff amount on Indian ...

"The \$500 billion India-U.S. trade deal, with reciprocal tariffs rationalized to 18%, represents a structural inflection point for India's energy industry -- particularly on the export front," stated ...

[Get Price](#)



Contact Us

For catalog requests, pricing, or partnerships, please visit:
<https://www.pienaarshof.co.za>

