

PIENAAR ENERGY (PTY) LTD

Barbados Outdoor Energy Storage Cabinet 100kW



Barbados Outdoor Energy Storage Cabinet 100kW



Outdoor Energy Storage Cabinet 215kWh

Propagation Prevention: Housed in individual IP54-rated metal cabinets designed to prevent fire propagation between units. Modularization and Scalability: The system is flexibly scalable at both the ...

[Get Price](#)

Barbados Outdoor Energy Storage Cabinet Wholesale: Powering ...

About Us: Specializing in commercial-scale energy storage since 2008, we deliver turnkey solutions for tropical regions. Our products serve solar farms, resorts and industrial facilities across 23 island nations.



[Get Price](#)



100kW 215kWh All-in-One Battery Storage Cabinet

The iCON 100kW 215kWh Battery Storage System is a fully integrated, on or off grid battery solution that has liquid cooled battery storage (215kWh), inverter (100kW), temperature control and fire safety ...

[Get Price](#)

Barbados outdoor energy storage power supply cabinet

100KW Outdoor Cabinet Energy Storage System (Air-Cooled) which can improve power quality, load tracking, backup power supply, peak shaving, and valley filling.

[Get Price](#)



Commercial and Industrial Energy Storage Cabinet BESS , Anern

Details of 100KW 215KWH Outdoor Cabinet Commercial and Industrial Energy Storage System All-in-One Design: Compact, pre-assembled solution for easy deployment and reduced installation time. ...

[Get Price](#)

100KW/215KWh All-in-One Outdoor Lithium ...

Our standard cabinet comes with fire system isolation, state-of-the-art liquid-cooling technology, combustible gas detection, and an FM200 fire ...

[Get Price](#)



100kW/215kWh Air Cooling BESS System , Scalable Power Unit



This integrated cabinet combines power modules, batteries, cooling, fire protection, and real-time monitoring in a single rugged unit. PV-diesel hybrids, and solar charging stations.

[Get Price](#)

100KWH/215KWH 768v 280Ah 3phase HV outdoor LiFePo4 BESS

Our Outdoor 100KW/215KWH Cabinet Energy Storage System boasts several notable advantages. Firstly, its modular design ensures easy installation and maintenance, with the flexibility to scale

...

[Get Price](#)

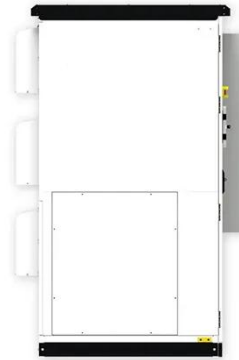

100KW-215kWh Outdoor Cabinet Energy Storage System (Air-Cooled)

Discover the advanced 100KW-215kWh Outdoor Cabinet Energy Storage System with air-cooled technology. Ideal for peak shaving, backup power, and enhancing renewable energy use in industrial ...

[Get Price](#)

Outdoor Cabinet BESS Lithium

Battery 100kWh Barbados

The Highjoule 100KWh Outdoor Cabinet Series (HJ-G20-100F/HJ-G50-100F; HJB-G20-100F/HJB-G50-100F), equipped with LFP/SSB 3.2V/280Ah batteries, offers 98.4% efficiency and >8000 charge ...

[Get Price](#)

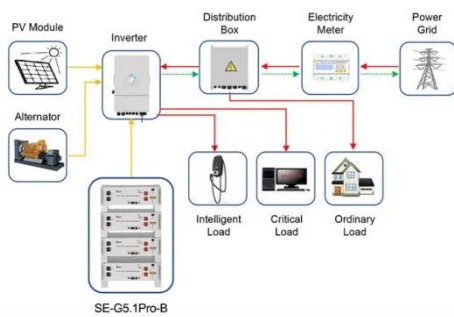
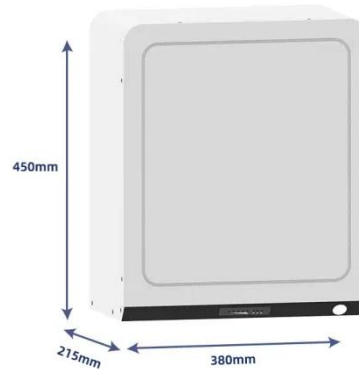

Application scenarios of energy storage battery products

100KW/215KWh All-in-One Outdoor Lithium Inverter Battery Energy Storage

Our standard cabinet comes with fire system isolation, state-of-the-art liquid-cooling technology, combustible gas detection, and an FM200 fire extinguishing system, ensuring the safety and ...

[Get Price](#)

Contact Us

For catalog requests, pricing, or partnerships, please visit:
<https://www.pienaarshof.co.za>

