

PIENAAR ENERGY (PTY) LTD

350kW Outdoor Storage Unit for Water Treatment Plant in Papua New Guinea



350kW Outdoor Storage Unit for Water Treatment Plant in Papua New Guinea



Fimali , Water & Waste Water Systems, Industrial Sales

Fimali is a nationally owned business providing goods and services for Water and Wastewater/Sewage Treatment in Papua New Guinea.

[Get Price](#)

Containerized Energy Storage Solutions in Papua New Guinea: ...

Summary: Papua New Guinea (PNG) faces unique energy challenges due to its rugged terrain and dispersed population. Containerized energy storage systems (CESS) offer scalable, reliable power ...

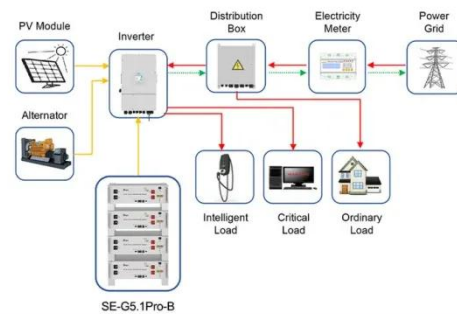

Application scenarios of energy storage battery products

[Get Price](#)



Water Supply , Niuwara PNG Ltd

From small village treatment packages through to mining/gas camp water treatment Niuwara has got you covered. Niuwara PNG Ltd designs, supplies, installs, and commissions sewage treatment ...

[Get Price](#)

Papua New Guinea Water Storage Systems Market (2024-2030)

Historical Data and Forecast of Papua New Guinea Water Storage Systems Market Revenues & Volume By Onsite water & wastewater collection for the Period 2020-2030



- TELECOM CABINET
- BRAND NEW ORIGINAL
- HIGH-EFFICIENCY

[Get Price](#)



Storage Tank In Papua New Guinea

Our company is managed to attain the position among the top Storage Tank Exporters and Suppliers in Papua New Guinea. If you want impeccable products, discuss your requirements with our experts.

[Get Price](#)

SMART WATER STORAGE AND TREATMENT SOLUTION FOR ...

MAK Water, an Australian water treatment reliability and maintenance specialist, was chosen by Exxon Mobil to design and construct a potable water treatment plant for their LNG facilities in Port Moresby, ...

[Get Price](#)

BMS Wiring Diagram

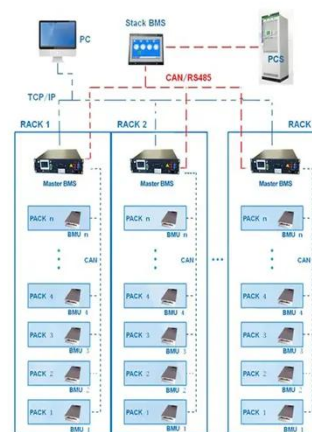

PNG LNG FACILITY EXPANSION NEW WASTEWATER ...



Centurion Water & Wastewater Solutions is delivering a modular Sequencing Batch Reactor (SBR) wastewater treatment plant for an LNG project in Papua New Guinea, designed to support a growing ...

[Get Price](#)

water-storage-tanks Companies serving Papua New Guinea

We are Fluidesa, a company that offers precise, reliable and profitable services and products for the dosing of reagents, water treatment and operation of potable and residual treatment plants (industrial ...



[Get Price](#)

Outdoor Energy Storage Solutions in Papua New Guinea: Key Trends ...

Papua New Guinea's rugged terrain and growing energy demands make outdoor energy storage cabinets a critical component for reliable power distribution. This article explores the unique ...

[Get Price](#)



Smart Water Storage and

Treatment Solution for LNG Facilities in ...

When ExxonMobil's massive PNG LNG project needed reliable water and wastewater treatment infrastructure, Coerco partnered with MAK Water to supply custom-engineered poly tanks ...

[Get Price](#)



Contact Us

For catalog requests, pricing, or partnerships, please visit:
<https://www.pienaarshof.co.za>

