

PIENAAR ENERGY (PTY) LTD

100w liquid cooling energy storage

215kWh

8,000+ Cycles Lifetime

IP54 Protection Degree



Overview

The 100kW/241kWh liquid cooling energy storage system adopts an “All-In-One” design concept, with ultra-high integration that combines energy storage batteries, BMS (Battery Management System), PCS (Power Conversion System), fire protection, air conditioning, energy management, and. The 100kW/241kWh liquid cooling energy storage system adopts an “All-In-One” design concept, with ultra-high integration that combines energy storage batteries, BMS (Battery Management System), PCS (Power Conversion System), fire protection, air conditioning, energy management, and. The 100kW/215 kWh liquid energy storage system features a prefabricated cabin design flexible deployment, convenient transportation, and no need for internal wiring and debugging. It responds quickly, boasts high reliability, and offers functions such as peak shaving, power capacity expansion. Experience enhanced performance and smart thermal management with the Sunway 100kW/261kWh Liquid-Cooled Energy Storage System. It is widely used in the energy storage field with grid-tied and off-grid inverters. High specific heat liquid cooling technology. Modular “All-In-One” integrated single cabinet design. Equipped with integrated EMS for smart energy management, liquid cooling for efficient operation, and durable LiFePO4 batteries with over 6,500 cycles, it offers. Greenwatt FH series industrial and commercial storage outdoor integrated cabinet is suitable for various industrial and commercial application scenarios such as industrial parks and commercial complexes.

100w liquid cooling energy storage



LIQUID COOLING ENERGY STORAGE SYSTEM ...

It responds quickly, boasts high reliability, and offers functions such as peak shaving, power capacity expansion, emergency backup power, grid balancing, capacity management, and multi-level parallel ...

[Get Price](#)

100kW Liquid Cooling Storage , Max Efficiency

Maximize green energy with our 100kW liquid-cooled storage. Durable, efficient, and ready for any climate. Click for a sustainable future!



[Get Price](#)



230Wh/100KW Liquid Cooling C& I Energy Storage System

Excellent Performance: 100kW energy storage inverter, wide output voltage range, equipped with grid-connected voltage adaptation system, three-phase voltage balance control system, and grid harmonic rate control system.

[Get Price](#)

GSL Energy , 100kW 232kWh C& I Liquid Cooling Cabinet Energy Storage

Equipped with integrated EMS for smart energy management, liquid cooling for efficient operation, and durable LiFePO4 batteries with over 6,500 cycles, it offers reliable, scalable energy solutions.

[Get Price](#)



100KW 232KWH Liquid Cooling ISEMI Lithium-ion Battery Energy Storage

Container-Type ESS Air-Cooled / Liquid-Cooled. The commercial & Industrial energy storage system integrates batteries, battery management system, energy management system, modular power conversion system and ...

[Get Price](#)

GSL Energy , 100kW 232kWh C& I Liquid Cooling ...

Equipped with integrated EMS for smart energy management, liquid cooling for ...

[Get Price](#)

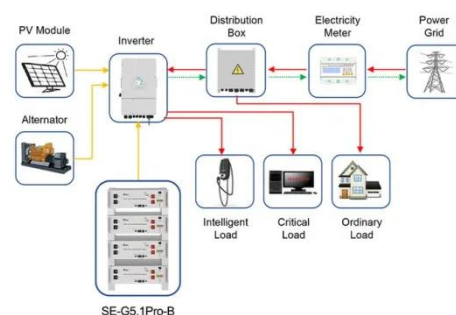

Application scenarios of energy storage battery products

100kW/241kWh Liquid Cooling Energy Storage System

The 100kW/241kWh liquid cooling



energy storage system was independently designed and developed by EVB. It is widely used in the energy storage field with grid-tied and off-grid inverters.

[Get Price](#)

Greenwatt 100KW PCS+261Kwh Liquid Cooling Energy Storage System

Compactness & Efficiency: Liquid cooling components can be more compact than large air ducts and fans for the same cooling power. The system itself can also run its pumps more quietly and efficiently.



[Get Price](#)



100KW232KWH Liquid Cooling Cabinet energy storage ...

It integrates EMS, advanced liquid cooling technology, and high-quality LiFePO4 batteries to ensure safety, efficiency, and longevity. Ideal for peak shaving, valley filling, and microgrid systems, this IP54-rated cabinet ...

[Get Price](#)

Sunway Intelligent liquid- cooled 100KW 261KWH ...

With advanced liquid cooling, IP55 protection, and rapid deployment capability, it's a powerful and safe energy storage solution ready for demanding environments.

[Get Price](#)



Highly Efficient 100KW 215kWh Liquid Cooling Lithium Battery for

Liquid Cooling 100KW 215kWh Lithium
Battery For Commercial And Industrial
Battery Energy Storage System FOB
Shipping: Express Delivery

[Get Price](#)

Contact Us

For catalog requests, pricing, or partnerships, please visit:
<https://www.pienaarshof.co.za>

